



# Transmission

DECEMBER 2024



Official Magazine of the  
**ROOTES** GROUP CAR CLUB QLD Inc  
(Incl Humber, Hillman, Sunbeam, Singer, Commer &  
Karrier Vehicles and Clubs in Queensland)  
*Just one of the many benefits of membership*

# PRESIDENT'S REPORT

It is amazing how quickly 2024 has passed with the variety of events we have held during this year.

So, on reflection what were our priorities for 2024 and how did we meet those priorities during the year?

When I took on the President's role at the beginning of the year, I had in mind three priorities for the Club to achieve.

Firstly, we needed to look at getting you as members a complete listing of the events for the year so that you could plan in your busy schedules which events you would like to attend. This included the standard events such as the Rootes Roundup, Macs Bridge and All British Day. In addition, we added in two events with other car clubs such as the Ipswich Veteran and Vintage Car Club in June and the Blackall Range Horseless Carriage Club in October. I would like to continue in the same vein in 2025 by participating in joint runs with other car clubs as it allows us to meet other like-minded enthusiasts and view different makes and models of other classic cars.

Secondly our Club had a major commitment in supporting the Sunbeam Nationals held in Montville during early September. This was by all accounts a great event with over eighty attendees and thirty-two cars on display from NSW, Victoria, South Australia, Western Australia and of course Queensland. The Organising Committee of Clyde Northcott, Gayle and Rob Heiner and Bob Otto were fantastic, and it would have to be one of the best Nationals I have attended.

Thirdly I was focusing on encouraging our members to attend as many events as possible during the course of the year. The Club is only as good as its members attending the events we organise so as members how do you think we went this year?

Sadly during 2024 we must remember the passing of Les Whelan, Nancy Hills, Ranald Grant and Bill Feeney who all made significant contributions to the Club over their many years of car ownership. I also send our thoughts to our Vanuatu members John and Sandy Warmington who are enduring the aftermath of the recent earthquake.

We are holding the AGM in early 2025 the details of which are in the Newsletter this month (March 16<sup>th</sup>, Arana Leagues Club starting at 09:30 then to lunch – Ed). I would strongly encourage you to attend and would really value your input on how the Club can meet your expectations going forward in 2025.

Unfortunately, the President's Mystery Run in early December which was to take us on a scenic drive to Beaudesert and beyond had to be cancelled due to the inclement weather however I will add it into the 2025 Events Calendar.

I know Christmas has now recently passed us, so on behalf of your Committee I would like to wish you a belated Happy Christmas and New Year and look forward to seeing you in 2025.

I will be taking our annual month off in February to attend the Sunbeam and the Humber car club Nationals on the North Island of New Zealand which are two weeks apart.

Enough from me, I will look forward to meeting many of you at my mystery run and the AGM next year, and if you have any suggestions, comments or questions please feel free to contact me directly at [elizabethkindy@westnet.com.au](mailto:elizabethkindy@westnet.com.au)

David Phillips.

**Don't Forget: Next Event**

**Australia Day Show 'n' Shine – Ormiston State School - Cleveland**

**See details and map in this newsletter.**

**Don't Forget: Membership Renewals Due 1<sup>st</sup> January**

# UPCOMING EVENTS CALENDAR

Do you have an idea for a run or event? Please contact the Events Co-ordinator! Thank you.

Month	Date	Day	Event / Address	Address	Sponsor	Start
Jan	18 <sup>th</sup>	Saturday	Rosewood Charity Show n Shine	Rosewood Bowls Club	Barbara 0412 140 239	14:00
Jan	26 <sup>th</sup>	Sunday	Australia Day Rally	Ormiston State School – Cleveland	Bayside Restorers	06:00
Jan	26 <sup>th</sup>	Sunday	Australia Day Show n Shine	Glasshouse Mountains Sports Club Steve Irwin Way, GlasshouseMntns	Glasshouse Sports Club	
Jan	26 <sup>th</sup>	Sunday	Allora Heritage Day	Allora Showgrounds Also Saturday 25 <sup>th</sup>		
Feb	1 <sup>st</sup>	Saturday	Toowoomba Swap	Toowoomba Showgrounds	Darling Downs VVMC	
Feb	2 <sup>nd</sup>	Sunday	Toowoomba Swap	Toowoomba Showgrounds	Darling Downs VVMC	
Mar	16 <sup>th</sup>	Sunday	AGM	Arana Leagues Club	RGCCQ	09:30

- ITEMS IN BLUE: CLUB ORGANISED EVENTS
- ITEMS IN BLACK: EVENTS ORGANISED BY THIRD PARTIES

## REGULAR CAR MEETS AROUND BRISBANE

This is NOT a complete list. If you can recommend another, let us know so we can add it to our list.

Old Petrie Town, Petrie-Fri nights, Sat and Sun morning, every week.

1st Saturday of month 7.30 am - Cars and Coffee -Samios Foods Turbo Drive Coorparoo

1st Sunday of month 7.00 am - Greg's Cars and Coffee-Victoria Point Shops

2nd Sat of month 7.30 am - Coffee, Crunch and Chrome - Joes Diner - Kingsford Smith Dr. Eagle Farm

2nd Sunday of month 7.00 am Cars and Coffee - Spokes Café, Samford Village

Last Saturday of month 8.00 am Cars and Coffee - Ormeau, 270 Lars Rd.

Last Sunday of month 8.00 am Breakfast and Cars, Beenleigh Historic Village

2nd Sunday of month 10.00 am Waterloo Bay Hotel -Berrima St Wynnum

Wednesdays 5-8pm - Morayfield Cars and Pizza, Shops at Uhlmann Ave, Burpengary East

**Don't Forget: Next Event**

**Australia Day Show 'n' Shine – Ormiston State School - Cleveland**

**See details and map in this newsletter.**

**Don't Forget: Membership Renewals Due 1<sup>st</sup> January**

# R.G.C.C.Q.

## JANUARY EVENT

### Australia Day Show 'n' Shine

**From 06:00 a.m. Sunday 26<sup>th</sup> January 2025**

**Ormiston State School 82-110 Gordon Street Ormiston.**

On Australia Day (26th January), the Bayside Vehicle Restorers Club Inc. will hold its annual Australia Day Rally, which will be one of Queensland's largest rallies for historic and classic vehicles, with more than 500 vehicles expected to attend the day.

Entry is free and open to all lovers of old and classic vehicles. Just turn up. Free Breakfast is available to all.

•Free tea or coffee is provided to all •Magnificent vehicle display •Fantastic vehicle runs •Great raffle prizes

Proceeds of the Raffle go to the Sailability Charity, and other local charities

The day starts from 6.00am with free breakfast, tea and coffee and the opportunity to purchase a raffle ticket to support the Sailability charity. Serving of the free BBQ breakfast will stop at around 9:00am, however the free tea and coffee will be available all morning.

After breakfast at about 9.30am the raffles will be drawn and if your name is drawn out, proceed to the tuckshop area to collect your prize. After the raffles, you will have time to spend looking at the display of around 500+ classic vehicles parked in the grounds of Ormiston State School.

Buy some raffle tickets for a chance to win one of dozens of prizes. All the proceeds from ticket sales will be donated to Sailability a local charity enabling disabled people to Sail on Moreton Bay, and other charities.

Enjoy your morning tea at the school grounds. At about 10.30am leave on one of the several interesting drives (rally runs) visiting some of the Redlands' tourist spots. The runs will all finish at a local park, so make sure you pack your chairs, coffee cups, and lunch.

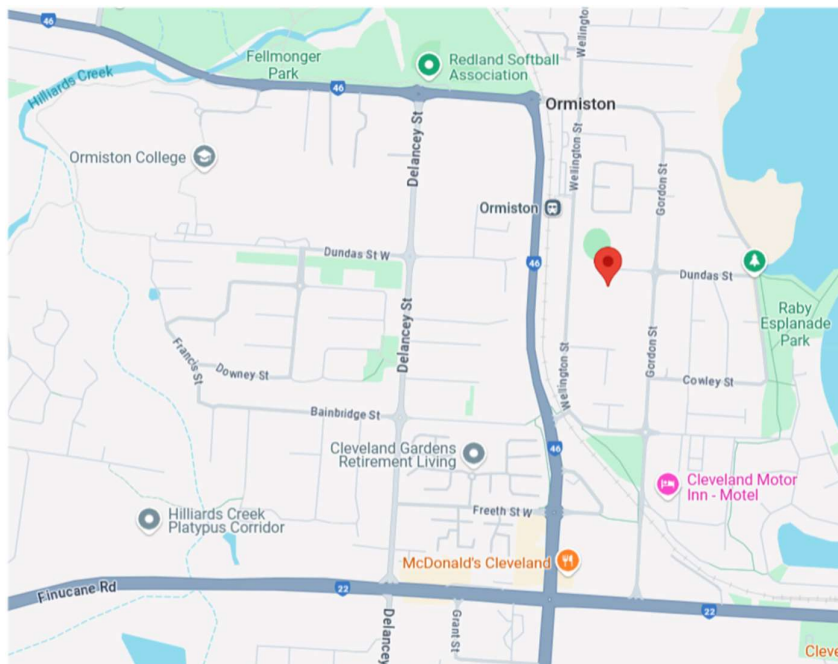



**Your Membership Dues for 2025 are due by January 1<sup>st</sup> 2025. No price increase from 2024.**

We've enjoyed having you on board with us for 2024 and look forward to continuing our association throughout 2025. As always, club fees for the year are due in January and once again we have managed to keep them down to just \$45 for the year – excellent value for money. No further reminders are sent, so please act on this form.

It is our duty to remind Members who are on S.I.V.S Concessional Registration that Department of Transport and Main Roads conditions state “to retain the concession you should be a financial member of an incorporated car club”. If you operate outside of these conditions of the SIV Scheme, you may face a fine of \$176 or risk having your concession eligibility reassessed. As well as incurring financial penalties for operating outside of the scheme, you may face serious insurance implications if you are involved in an incident causing damage to your or other vehicles or property, or injury to yourself or others whilst not being compliant with registration requirements due to lapsed membership.

**PAYMENT (Note – the Club has changed the Bank Account Details. Please check the account details below before processing your EFT payment, and update the Club's details in your Saved Payee list if necessary).**

Cheques/money orders payable to ROOTES GROUP CAR CLUB QLD Inc can be sent to:  
RGCC Qld Inc  
C/- P O Box 504  
Cannon Hill, QLD 4170

Alternatively, you may make a counter deposit or electronic transfer at any bank to:  
ROOTES GROUP CAR CLUB QLD Inc  
**BSB 484 799** (Suncorp) **ACCOUNT: 481 960 636**

(Please reference the deposit with your name and also send us an email when payment is made to make the Treasurer's life a little easier! (secretary@rgccqld.org.au)

#### **CHANGES/ADDITIONAL INFORMATION**

If there have been any changes since your last contact with us (for example: additional vehicles to be included in your membership, change of address, registration numbers, contact details, email address, etc), or if you now have information such as chassis numbers or engine numbers that you weren't able to provide at the time of joining please include those updates here. (Or, in the case of paying electronically please include a note in your advice email.) The Club is required to keep a record of SIV's registered cars for TMR. Please assist us by detailing any SIV's registered cars you may have.

A friendly reminder: If you own a Classic Car on SIV rego, then you must be a financial member of an Official Club. Failure to do so means your car is unregistered, uninsured if driven in QLD.



# ROOTES GROUP CAR CLUB OF QUEENSLAND INC



## 2025 MEMBERSHIP

Postal: Please fill out this form and forward with your cheque or money order payable to: ROOTES GROUP CAR CLUB QLD Inc. Send to RGCCQ Inc C/- PO Box 504, Cannon Hill QLD 4170

Online: Please fill out this form, pay by EFT and email the completed form to [secretary@rgccqld.org.au](mailto:secretary@rgccqld.org.au). Please include your surname in the transaction field.

Suncorp Internet Banking (Rootes Group Business Premium)

**BSB 484 799 Account 481 960 636**

This will renew your membership and update any changes to your address, cars, etc.

---

Name: .....

Address: .....

.....

Email address: .....

Phone No. .... Mobile No. ....

Please list all your Rootes Group vehicles.

Model ..... Year ..... Reg No. ..... Colour .....

.....

unregistered  on full registration  on concessional club registration

Model ..... Year ..... Reg No. ..... Colour .....

.....

unregistered  on full registration  on concessional club registration

Model ..... Year ..... Reg No. ..... Colour .....

.....

unregistered  on full registration  on concessional club registration

Model ..... Year ..... Reg No. ..... Colour .....

.....

unregistered  on full registration  on concessional club registration

Model ..... Year ..... Reg No. ..... Colour .....

.....

unregistered  on full registration  on concessional club registration

I enclose a cheque / money order for Standard Membership \$45.00

## DECEMBER EVENT – President’s Southside Mystery Run

It’s sunny as I type this on Boxing Day, but by the time you are reading this it’ll likely be raining again. So, it was on the day of the President’s Run in early December so the decision was sadly made to cancel the event. No doubt it will run sometime in 2025 and we look forward to seeing you there.

## Club Regalia – Stock up For 2025!

Your club has a good collection of Regalia items for sale – perfect indulgences!

Prices as shown, freight extra. Come along to an event and save on freight!

Contact your Club Regalia Officer Lyn Phillips by email at [admin@woolishop.com.au](mailto:admin@woolishop.com.au) or on 0402 423 800



**Polo Shirt with pocket** – Sizes L (4 available), XL (1 available), 2XL (2 available)

Made from “Podium Cool” fibre especially designed to absorb body perspiration into the fabric surface where it is evaporated leaving the wearer fresh and cool. Limited availability means wearers will enjoy exclusivity!

Price: \$25.00 each or 2 for \$40.00

Note – sensational male model not included.





**Bucket Hat** (5 available) and **Baseball Cap** (8 available)

One size fits most – most of us who don't want skin cancer that is. Price: \$15.00 each or 2 for \$20.00

**Window Transfers.**

Self-adhesive “stickers” designed to affix to the inside of a window – whether that's your shed door, car window or trophy cabinet. Wear your Rootes addiction with pride!

16 Available – 80mm diameter. Price: 2 for \$8.00

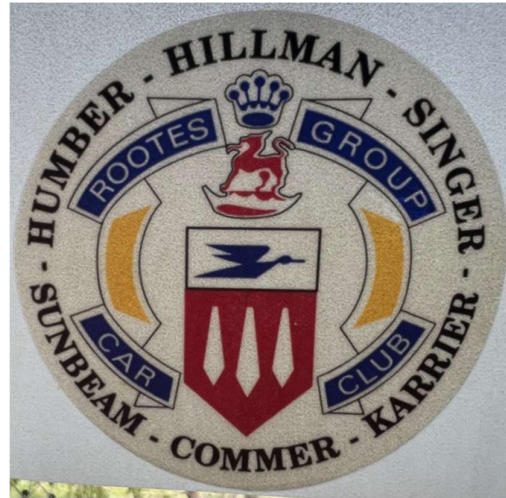

28 Available – 86 mm Square. Price: 2 for \$8.00



High Quality **leather key ring** with enamelled plaque and brass ring. 12 Available. Price: \$10 each.



Heavy (100 grams each or 10 per kilo!), quality **plaques**. Both sides of a single item shown below. Perfect badge bar or shed art – also proven to work as a coaster. 6 Available. Price: \$5 each or 4 for \$15.00

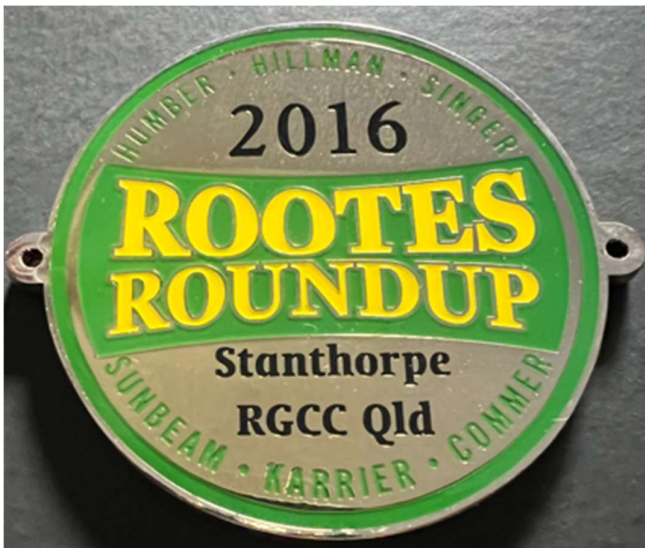

**Enamel badge** – 80mm W x 52mm H. 1 only, \$5.



**Sticker** – 72 mm diameter. 6 Available 2 for \$8.00

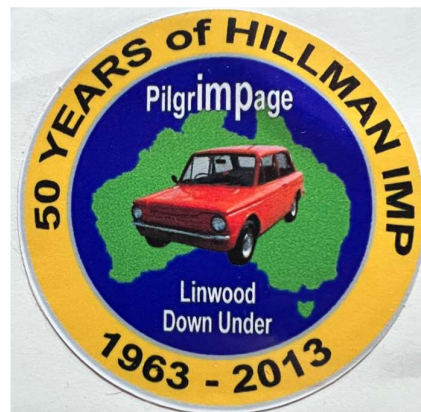





# HUMBER NATIONAL RALLY 2025

HOSTED BY HUMBER CAR CLUB OF AUSTRALIA INC.

CO-HOSTED BY PARKES ANTIQUE MOTOR CLUB

FRI 16TH - MON 19TH MAY 2025



## ENTRY FORM

**Entries close 21 March 2025**

Please use **BLOCK LETTERS** with blue or black pen

SECTION 1 - ENTRANT DETAILS				
Surname:		Given Name:		
Postal Address:				
		State:		Postcode:
Phone:		Email:		
Car Club Membership:				
SECTION 2 - VEHICLE DETAILS				
Make:		Model:		
Body Style:		Year:	Registration No:	
SECTION 3 - PASSENGER DETAILS				
PASSENGER NAMES (For Name Badges. Please include age where passenger is 15 years or under)				
1.		3.		
2.		4.		
PASSENGER SPECIAL DIETARY REQUIREMENTS (SPECIFY)				
1.		3.		
2.		4.		

## REGISTRATION & ENTRY FEE

REGISTRATION \$ 50.00  
PAYMENT OF ENTRY FEES \$160 per person x \_\_\_\_\_ = \$ \_\_\_\_\_  
TOTAL AMOUNT PAYABLE \$ \_\_\_\_\_

Entry Fee includes all admissions, Welcome, Rally Dinners Saturday and Sunday, Farewell (Refer to Program in Section 4 for specific inclusions and any extra out-of-pocket expenses)

**Please pay via direct deposit (no cheques):**

**BSB: 032 183 A/C Number: 192258 A/C Name: Humber Car Club of Australia**

**Please reference the deposit with your initial and surname (e.g. A Jones) + Rally**

Receipts will be sent to entrant's email address.

### ENTRANT DECLARATION:

**Please tick**

- The vehicle entered has current Conditional Historic Registration or Full Registration and Comprehensive or Third Party Liability Insurance as at the dates of the Rally.
- I am a financial member of the above stated Club.
- I will be able to produce evidence of current Club Membership, Registration and Vehicle Insurance at Rally Registration.

**SIGNED:** \_\_\_\_\_ **DATE:** .....

### SUBMISSION OF ENTRY FORM

**Jotform Link (preferred)**

<https://form.jotform.com/242181901158049>

**Or by email your entry to:** [pjwright18@bigpond.com](mailto:pjwright18@bigpond.com)

**If you need to post:** Peter Wright,  
9 Windmill Drive  
MOORE CREEK NSW 2340

## SECTION 4 – PROGRAM AND INCLUDED COSTINGS

PROGRAM	ACTIVITY All activities are included in the entry fee unless costed otherwise	DETAILS	COST INCLUDED OR AT PARTICIPANT EXPENSE
Friday 16 <sup>th</sup> 2.00 pm	Parkes Visitor Information Centre Access to “King’s Castle”, Moat Cottage and Motor Museum Registration in Parkes Antique Motor Club Rooms		Cost Included
4.00 pm	Afternoon Tea and Official welcome	Catered by Parkes Antique Motor Club	Cost Included
6.30 pm	Dinner at Participant choice and expense.	Group booking will be made at Cambridge Hotel	Own expense
Saturday 17 <sup>th</sup> 9.00 am	Vehicle Display and Judging. “Graceland Gates” Co-hosted by Parkes Antique Motor Club	Judging by Parkes Antique Motor Club	
12.30 pm	Entry to Henry Parkes Museum and Morning Tea included.  Lunch at Participant choice and expense.	Catered by Henry Parkes Museum  Select your own venue	Cost Included Cost Included Own Expense
2.00 pm	Visit to HARS Parkes Aviation Museum	Guided Tour. Afternoon Tea by HARS Parkes	Cost Included
6.30 pm	Dinner and Quiz Night at Parkes Services Club	Advise any special dietary requirements. 2 Course buffet meals, tea and coffee included. Bar will be open.	Cost included Own Expense
Sunday 18 <sup>th</sup> 9.00 am	Drive to Peak Hill Gold Mine Guided Tour of Mine	Included	Cost Included
11.45 am	Light Morning Tea at Commercial Park, Peak Hill	Provided by HCCA	
	CSIRO Parkes Observatory “The Dish” Note: Closes at 4.00 pm.  “3D” Video an Extra	Included	Cost Included Own Expense
	Free afternoon to visit sites of Parkes	Participant Expense Lunch can be purchased at the café at your own expense.	Own Expense
6.30 pm	Rally Dinner Quiz Night, Presentation and Banner Handover	Advise any special dietary requirements. 2 Course alternate drop meal, tea and coffee included. Bar will be open.	Cost Included Own Expense
Monday 19 <sup>th</sup> Farewell		Included Included	Included Included

# SUNBEAM 46<sup>TH</sup> NATIONAL IMAGES LIBRARY

There is a large quantity of photos and videos available at the links below, until January 31<sup>st</sup> 2025.

Photos:

[https://drive.google.com/drive/folders/1w5-bMbg-xfR5kSkq\\_vpgzr17fHS41Zru?usp=drive\\_link](https://drive.google.com/drive/folders/1w5-bMbg-xfR5kSkq_vpgzr17fHS41Zru?usp=drive_link)

Videos:

[https://drive.google.com/drive/folders/1Yse4FhwTpkYF\\_tNWJPGOSKM4Qph-FvJw?usp=drive\\_link](https://drive.google.com/drive/folders/1Yse4FhwTpkYF_tNWJPGOSKM4Qph-FvJw?usp=drive_link)

**The 2025 Sunbeam Nationals will be at Victor Harbor in South Australia from 12<sup>th</sup> to 15<sup>th</sup> September – hope to see you there!**

## ROOTES GROUP CAR CLUB QLD Inc

Postal: PO Box 504, Cannon Hill, Q 4170  
 Email: [secretary@rgccqld.org.au](mailto:secretary@rgccqld.org.au)  
 Facebook: [facebook.com/RootesGroupCarClub](https://www.facebook.com/RootesGroupCarClub)  
 Website: [www.rgccqld.org.au](http://www.rgccqld.org.au)  
 Instagram: [@rootesgroupcarclubsaustralia](https://www.instagram.com/rootesgroupcarclubsaustralia)  
 Portal: [rootesgroupqueensland.jimdo.com](http://rootesgroupqueensland.jimdo.com)

**Affiliated with the QUEENSLAND HISTORIC MOTORING COUNCIL INC email: [qhmc.net.au](mailto:qhmc.net.au)**

President	David Phillips	0402 423 800
Vice President	Adrian Grant	0434 383 055
Secretary	Lyn Phillips	0402 423 800
Treasurer	Neville Kennard	0407 485 597
Events Manager	Con Krallis	0402 202 784
Librarian	Adrian Grant	0434 383 055
Spare Parts	John Harris	07 3341 5555
Rootes Registrar	Neville Kennard	0407 485 597
Humber Registrar	Jean Bennett	
QHMC Representatives	Adrian Grant	0434 383 055
Webmaster	Neville Kennard	0407 485 597
Magazine Editor	Clyde Northcott	<a href="mailto:korbenstrategic@bigpond.com">korbenstrategic@bigpond.com</a>
SIV's Compliance Officers	Garry Ellis Neville Kennard Christine Cartwright	0418 832 175 0408 485 597 0418 742 179
Regalia Officer	Lyn Phillips	0402 423 800
Management Committee	David Phillips	Adrian Grant
	Lyn Phillips	Neville Kennard
	Clyde Northcott	

© 2024 Rootes Group Car Club Qld Inc. Permission is granted for text and images to be reprinted by other Car Clubs which are associated with Rootes Group Vehicles. Acknowledgements to RGCC Qld Inc. must be included. Other non-profit entities please write requesting reprint permission.



**Club meetings are usually held on the 3rd Sunday afternoon of each alternate month. We're in this to enjoy ourselves, so meetings are fun and we enjoy a Nog 'n Natter beforehand. Friends and prospective members are ALWAYS welcome. The next scheduled Committee meeting is at a date to be advised.**



## 47th Sunbeam National Meeting 2025



A Victor Harbor Encounter  
September 12th - 15th 2025



Phone: 0417 458 736

E-mail: [nationals25@sunbeamcarclubsa.org.au](mailto:nationals25@sunbeamcarclubsa.org.au)  
web: <http://www.sunbeamcarclubsa.org.au/NationalsSA>  
register: Post to PO Box 112, Glenside SA 5065,  
or email to [nationals25@sunbeamcarclubsa.org.au](mailto:nationals25@sunbeamcarclubsa.org.au)





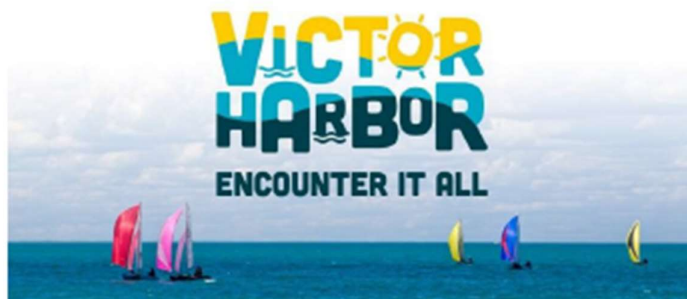

We look forward to your company at the 2025 Sunbeam Nationals in Victor Harbor, South Australia

The Sunbeam Car Owners Club of South Australia is delighted to host the 2025 Nationals and has selected the Fleurieu Peninsula city of Victor Harbor as the venue for the annual gathering.

Victor Harbor enjoys fine daily weather and pleasant evenings in spring, perfect for motoring and outdoor activities. These are very good reasons for selecting September 12<sup>th</sup> – 15<sup>th</sup> for our annual gathering.

Our program is designed to include only a few of the best experiences that the Fleurieu can offer, with an opportunity to extend your stay and participate in other features of the area.

We have found a comfortable balance in our program to provide you with time to indulge your motoring passion, mixed with a level of organised social activities but with free time to follow individual interests. You can choose your own level of culinary experiences to fit with your preferences and budget in comfortable and affordable accommodation.

It is now time for you to make your bookings and pay your deposits. You can do this by completing the Registration Form in this publication and posting it to us, or you can email it to us. You can then electronically pay your registration deposit or fees in full. Please note that cheques can no longer be accepted.

You will also need to book your accommodation directly with the McCracken Country Club.

**\*Please refer to important booking details in the "Accommodation Booking" section.\***

On behalf of the Sunbeam Car Owners Club of SA Inc and the 2025 Nationals organising committee, we look forward to your company at Victor Harbor.

Paul Heuer  
National Meeting 2025 Chairman



**We thank The Federation of Historic Motoring Clubs SA Inc for their support.**

## 47<sup>th</sup> Sunbeam National Meeting – Victor Harbor – 12<sup>th</sup> -15<sup>th</sup> September 2025

Name preferred for your name tag

Booking in the name of		
Address		
	postcode	
'phone	preferred daytime	mobile
email		
Club		
Names of other persons attending (name preferred for their name tag)	1.	2.
	3.	4.
Driver/Vehicle Details	Driver	
	Make	Model/Year
	Colour	Reg'n
Do you wish to enter your Sunbeam for judging? If yes, indicate which category.		
	Pre-War	Series Alpine
	Mark Alpine	Tiger
	Talbot	Rapier
	Post 1968 (include model)	
Do you have any dietary requirements?		
Do you have any disability or other special access needs?		
Office use only	Date entered to database _____	Deposit rec. _____ Balance rec. _____

Complete and post this registration to PO Box 112, Glenside SA 5065.  
 EFT your payment of \$280pp in full, or deposit of \$100pp to BSB 805 005, Account 100257162 (Sunbeam Car Owners Club of SA Inc) Please include your name and state as the transfer reference.  
**DEPOSITS REQUIRED BY 1<sup>st</sup> MARCH 2025, FINAL PAYMENTS BY 1<sup>st</sup> AUGUST 2025**  
**PLEASE NOTE THAT WE CAN NO LONGER ACCEPT PAYMENT BY CHEQUE**  
 Arrangements for other payment instalments can be made on request.  
 You can also scan and then email your registration to [nationals25@sunbeamcarclubsa.org.au](mailto:nationals25@sunbeamcarclubsa.org.au)  
 A copy of this Registration Package and form can be found at <http://www.sunbeamcarclubsa.org.au/Nationals-SA>

## Club Regalia

See the special promotion in this newsletter. Get in quick – or miss out 😊

## Impromptu Events / COVID

Financial / Current Members – create your own impromptu event.

Lead others to a favourite spot of your choosing and enjoy their company in their classic cars.

Remember to carry a copy of the impromptu event approval with you when driving to and from any event.

It is also wise to carry a printed copy of the invitation / newsletter excerpt / webpage of any event you are travelling to and from in case you are pulled over for any reason.

The Management Committee recommend the following advice be offered to our members who may be contemplating taking part in Club activities in the future:

The Club's website has an Application Form that when fully completed is automatically sent to the Events Manager.

His job will then require resending the Application as an email to ALL members.

Accordingly, the Application will require a start time and those members wishing to take part in the Event will need to phone the Applicant to obtain the requisite details.

It is anticipated that these Impromptu Events will often take place during mid-week outside of the regular Club events.

You will be asked to obtain the names of attendees and for them to sign an attendance sheet.

See this on Facebook: <https://www.facebook.com/World-of-Rootes-Group-Cars> (Over 3000 photos)

See this on Facebook: [https://www.facebook.com/Rootes Group Buy or Sell Cars and/or Parts](https://www.facebook.com/Rootes-Group-Buy-or-Sell-Cars-and-or-Parts)

### WEARING OF SEAT BELTS—CLASSIC VEHICLES

The government camera scheme to detect wearing of seatbelts has been clarified by the Transport Main Roads with respect to wearing them whilst in a Classic car built prior to 1969 (when seat-belts were not installed when manufactured). A representative of the TMR has stated that all photos taken are cross-referenced with the vehicle registration details and if the vehicle is prior to 1969 and NO belts were fitted, NO FURTHER ACTION WOULD OCCUR—THE PHOTO WOULD BE DISMISSED.

However, if a photo was inadvertently processed and a summons was issued, contact TMR and they will deal with it in your favour.

### DISCLAIMER

Readers of this magazine are advised to use caution in following any technical or other advice that may be given in any article, as the Club and committee cannot accept responsibility for its accuracy or reliability. The views expressed by correspondents do not necessarily represent the views of the Club

### Don't Forget: Next Event

**Australia Day Show 'n' Shine – Ormiston State School - Cleveland**

**See details and map in this newsletter.**

**Don't Forget: Membership Renewals Due 1<sup>st</sup> January**

# HUMBER HOSPITALITY

A service offered by all Australian Humber car clubs, including ours.

A volunteer service of "tea and sympathy" (followed by help where possible) for members experiencing vehicle breakdowns while travelling interstate.

Please use this service responsibly and call for assistance only where you and / or the Automobile Road Service are unable to rectify the problem.

(ACT) Rod Calvert. Farrer. Phone: 02 6286 4035

(NSW) Bruce Carpenter. Maryland (Newcastle). Phone 0414 619 108

(NSW) Jack Harris. 218 Duff Street, Broken Hill 2880. Phone 08 8088 5843

(NSW) Roger Foote, Eastwood (Sydney). Phone 0448 HUMBER

(NSW) Denis Boyle. 51 Shelleys Lane, Thirlmere (SW Sydney). Phone 02 4683 0643 / 0478 047 690

(NSW) Alan Lindsay "Winamie" 595 Rocky Range Road Delegate (SE NSW). Phone 0428 588 083

(QLD) Lawrie and Jean Bennett. Carina (E Brisbane). Phone 07 3398 5062

(QLD) Adrian Grant. The Gap (W Brisbane). Phone 07 3300 3955 or 0434 383 055

(QLD) Max Webster. 576 Drayton Connection Rd, Finnie (Toowoomba). Phone 0418 716 268

(VIC) Bob Kennedy. Glenlyon (near Daylesford). Phone 03 5348 7692

(VIC) Keith Willimott. Watsonia (NE Melbourne). Phone 03 9435 6354

(WA) Brian and Rosemary Phillips. Gooseberry Hill (E Perth). Phone 08 9293 2674

(SA) Eric Austin. 14 Lindsay St, Highbury. (NE Adelaide). Phone 08 8337 6337

(SA) Winston Bryant. Blakeview. (near Gawler). Phone 0403 024 385

## MEMBERS OFFERING SERVICES

**Some of our club's members offer services that may assist you with your Rootes classic.**

Their contact details are listed here free of charge as a club service as part of their own club membership.

(Any errors or omissions please let us know, and we'll fix next issue..)

- **John Harris (Rootes Rochedale)** can assist with Rootes parts and mechanical services. Phone number (07) 3341 5555 email: [rootesro@outlook.com](mailto:rootesro@outlook.com)
- **CARB TECH:** Paul White at Redcliffe 0417 713 662 can service most makes of carburettors on Classic Cars
- **Frank Schoenberger:** manufactures most rubber products for Rootes Cars. [www.rootesautoparts.com](http://www.rootesautoparts.com)
- **Michael Pyne:** has a Tilt truck towing business 0438 717 665 email: [mvptow@gmail.com](mailto:mvptow@gmail.com)



## MEMBERS: CREATE YOUR OWN IMPROMPTU EVENT

LEAD OTHERS TO A FAVOURITE SPOT OF YOUR CHOOSING. ENJOY THEIR COMPANY IN THE CLASSIC CARS

REMEMBER TO CARRY A COPY OF THE IMPROMPTU EVENT WITH YOU WHEN DRIVING TO AND FROM ANY EVENT



## For Sale. 1938 Sunbeam Talbot 3 Litre Tourer

This car is one of five remaining in the world and is the only one in Australia, currently located at Paracombe (north east Adelaide S.A). Excellent provenance available including confirmation of build from Rootes UK, including shipment details. Chassis Number: 8684. This rare car is for sale. It is a chassis up restoration, but is only partially complete. Due to illness, I am unable to complete the body work. Tony Smith. 0429 700 059.

Already completed items include:

- Chassis stripped, repaired where necessary, sand blasted and painted
- Differential rebuilt (all bearings replaced)
- Gearbox rebuilt (all bearings replaced)
- Brakes restored (shoes all replaced)
- Master cylinder replaced
- All brake lines replaced
- Engine rebuilt installed and test run (runs like a dream)
- As body frame is coach built, all wood replaced where necessary
- Some body panels refitted to frame

All original parts are available to complete the restoration. Hundreds of photos of strip down are available for reference, they have been invaluable during the work so far. In addition, there is a workshop manual, original sales documentation and other supporting information.

Car has not been registered since 1977 (last registration sticker from Victoria, is still on the windscreen). I acquired the car in October 2005 and have been working on it, on and off, since then.

I would like to cover what I have spent on the vehicle, not interested in making a profit. I just hope that it goes to someone who is dedicated enough to complete the restoration. Just out of interest the last sale I have tracked the same model sold in U.K. for equivalent of \$A150,000. My asking price to cover costs so far is \$A20,000.

Following are some photos which might give people some idea of the vehicle.



Car as originally purchased



Chassis Number





Engine Left Side



Engine Right Side



Left Front



Interior Front



Interior Rear



Left Rear



Rear with Boot Lid



Right Drivers Door



# Useful Stuff – Galvanic Corrosion

Information provided by John Harris. Next month – test results.  
(Information provided is a guide only – always do your own research).

## CORROSION INHIBITORS FOR INTERNAL COMBUSTION ENGINE COOLING SYSTEMS

### 1. INTRODUCTION

This work was undertaken to evaluate commercially available corrosion inhibitors for cooling systems of automotive petrol, automotive diesel and stationary diesel engines.

As it was found that there were many of this type of product on the market, to carry out tests on all those known to be available would have been an extremely time consuming task. An initial survey conducted on products submitted showed that some distributors had very limited knowledge of the corrosion inhibiting properties of the product they were handling.

An approach was made to the Central Research Laboratories, General Motors Holden, Port Melbourne, where tests were being conducted on corrosion inhibitors of this type. This led to discussions with the Metallurgy Section of National Radiators (Manufacturing) Pty. Ltd., Noble Park, who had carried out a comprehensive survey of commercially available corrosion inhibitors over the preceding three years.

National Radiators' initial tests were carried out by using various commercially available inhibitors in the engine cooling systems of company vehicles. An idea of the amount of corrosion of critical metals such as lead, tin, copper and aluminium that subsequently occurred in these cooling systems was gained by analysing the cooling water at regular intervals. The analyses were carried out by atomic absorption spectroscopy. These preliminary tests were used to eliminate several products which were regarded as not providing adequate corrosion protection. Further tests were carried out on the remaining corrosion inhibitors according to the procedure outlined in Section 2 of this report.

Thus on the basis of information supplied by these two companies, a series of tests was conducted on four commercially available corrosion inhibiting compounds. For purposes of comparison two commercially available anti-freeze compounds, based on ethylene glycol, were also tested.

The products examined were as follows and at the time of writing this report all but one were still commercially available;

- (i) "ALFLOC 2000 Diesel Engine Cooling Water Treatment", distributed by Catoleum Pty Ltd, Botany, N.S.W.
- (ii) "ALFLOC 2001 Engine Cooling Water Treatment". This is no longer being marketed.
- (iii) "STOP 33, Automotive Coolant Corrosion Inhibitor", distributed by Desmor Pty Ltd, Hawthorn, Victoria.
- (iv) "NATRA, Radiator Coolant Conditioner" distributed by Natra Pty Ltd, Noble Park, Victoria.



- (v) "POWER PLUS, Antifreeze and Rust Inhibitor", distributed by Norman C. Porter Pty. Ltd., N.S.W.
- (vi) "CASTROL Antifreeze (Type P)" distributed by Castrol (Australia) Pty Ltd., Brooklyn. Victoria.

## 2. TEST PROCEDURE

Each product was tested according to ASTM Standard Method D. 1384-70; Corrosion Test for Engine Antifreezes in Glassware.

In this method, specimens of metal typical of those present in automotive cooling systems were totally immersed in the test solution with aeration for 336 hours at 88°C. The corrosion inhibitive properties of the test solution were evaluated on the basis of the mass changes incurred in the specimens. Each test was run in duplicate.

### 2.1 Test Solutions.

The test solutions were made up with each individual corrosion inhibitor listed in Section 1 dissolved in two types of water. One, a soft, relatively non corrosive type water and the other, a hard corrosive type water.

The inhibitors were made up in solutions with each of these water types at the manufacturer's recommended concentration, as set out hereunder.

- (i) "ALFLOC 2000" : 30 ml per litre of water
- (ii) "ALFLOC 2001" : 50 ml per litre of water
- (iii) "STOP 33" : 25 ml per litre of water
- (iv) "NATRA" : 28 ml per litre of water
- (v) "POWER PLUS" ANTIFREEZE : 250 ml per litre of water
- (vi) "CASTROL" ANTIFREEZE : 250 ml per litre of water

The two types of water used were

- (i) Melbourne reticulated water, City area.
- (ii) "Perth/Brisbane" Corrosive water. This was made up to the following composition, from Melbourne water, and was based on typical analyses of the Perth and Brisbane reticulated water supplies.

Na <sup>+</sup>	160 ppm
Ca <sup>2+</sup>	60 ppm
Mg <sup>2+</sup>	40 ppm
Cl <sup>-</sup>	280 ppm
SO <sub>4</sub> <sup>2-</sup>	50 ppm
HCO <sub>3</sub> <sup>-</sup>	160 ppm



## 2.2 Metal Specimens

The following metal test specimens, representative of cooling system metals, were used. They were arranged in electrochemical couples as illustrated in Figure 1.

- |                    |   |   |
|--------------------|---|---|
| (i) Steel          | : | AISI 1020 Cold Rolled Mild Steel                        |
| (ii) Copper        | : | Cold rolled ETP 99.9%                                   |
| (iii) Brass        | : | Cold rolled 70% Copper 30% Zinc                         |
| (iv) Solder        | : | 35% Tin 65% Lead  |
| (v) Cast Aluminium | : | BS 1490 Alloy LM 25, containing the following elements. |

Silicon	6.5 - 7.5%
Iron	0.5%
Copper	0.1%
Magnesium	0.2 - 0.4%
Manganese	0.3%

- (vi) Grey Cast Iron

## 3. APPARATUS

The apparatus was set up as illustrated in Figure 2. Temperature control was obtained by using a contact thermometer immersed in the solution contained in the beaker. This was connected to a relay switch which controlled the power supply to the hot plate. The temperature hysteresis was minimised by adjusting the "Simmerstat" control on the hot plate to 2. The temperature of the test solutions was stable at better than  $88 \pm 0.5^\circ\text{C}$ .

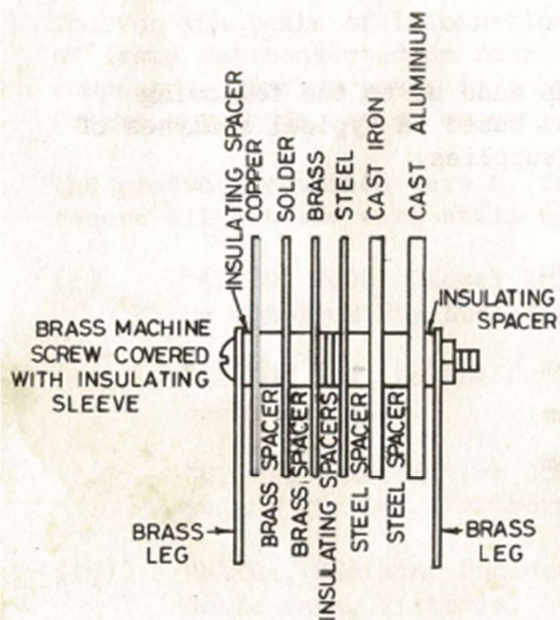

FIG.1 METAL SPECIMEN ARRANGEMENT

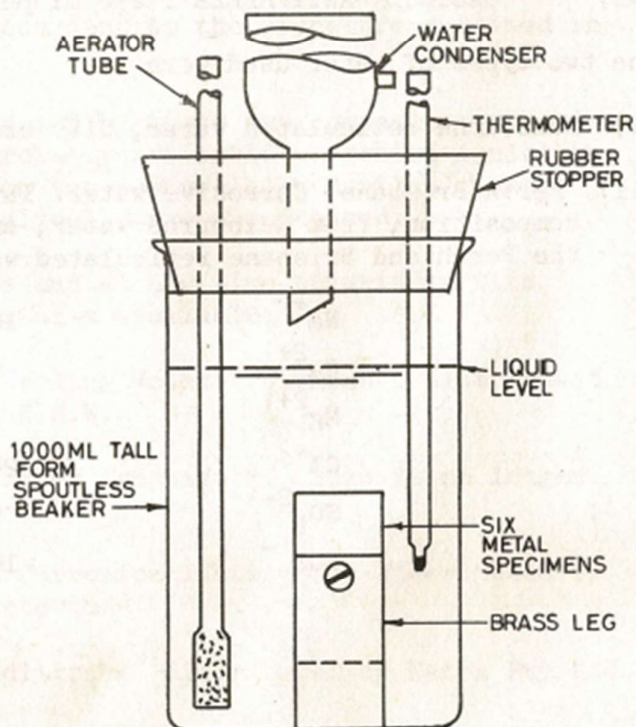

FIG.2 METAL SPECIMENS & EQUIPMENT FOR THE 336 h CORROSION TEST